



C400L

SPECIFICATIONS

ENGINE	
Manufacturer & Model	CUMMINS L9 Stage V
Cylinders & Displacement	6 cylinders / 543 CID (8.9 L)
Peak power at 1800 rpm (SAE J1995)	400 hp (298 kW)
Net Peak Torque	1 324 ft-lbf (1 795 Nm)
Fan	Automatic variable pitch, reversible
HYDRAULICS	
Pump System	4
Filtration	10 Microns
ELECTRICAL	
Voltage	12 Volts
Standard Light	8 LED type (4 Front, 2 Side, 2 Rear)
SERVICEABILITY	
Fuel Tank	132 gal US (502 L)
Hydraulic Reservoir	78 gal US (296 L)
Cooling System	10.6 gal US (40 L)

UNDERCARRIAGE & GROUND PRESSURE	
Chain Type & Size	Sealed and greased, D4 with an elevated final drive design
Track Shoe & Rollers	24 in (610 mm) single grouser with mud hole, dozer type rollers. 30 in (760 mm) pads optional
Ground Pressure (Crawler only, 24 in pads)	4.98 psi (0.35 kg/cm ²)
Weight (Crawler only, 24 in pads)	30 900 lb (14 016 kg)
Ground Pressure (Crawler only, 30 in pads)	4.09 psi (0.29 kg/cm ²)
Weight (Crawler only, 30 in pads)	31 700 lb (14 378 kg)
TOP SPEED	
Motor	Two speed hydraulic motors
Speed	Variable speed from 0 to 4.0 mph (0 to 6.5 km/h)
STANDARD CHARACTERISTICS	
- Push button cab lift with manual override	- Hydraulic oil filler pump
- Backup camera	- Air suspension seat
- AM/FM/Bluetooth radio	- ROPS/FOPS/OPS Certification
	- 12 Volts DC outlet

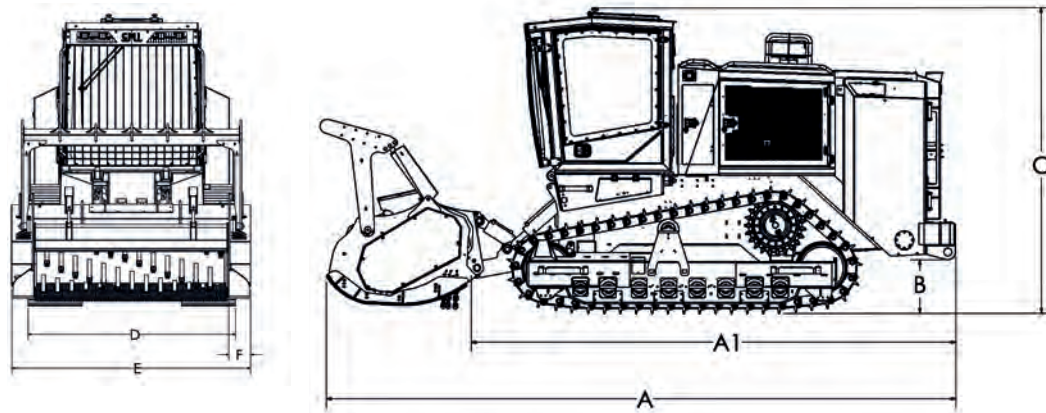

MACHINE DIMENSIONS

A - Overall Length with mulcher head (*): 268 in (681 cm)

A1 - Overall Length: 206 in (523 cm)

B - Ground Clearance: 22 in (56 cm)

C - Overall Height: 129.3 in (328 cm)

D - Overall width, 24 in (610 mm) pads: 92.1 in (234 cm)

D - Overall width, 30 in (760 mm) pads: 98.1 in (249 cm)

E - Mulching head overall width (*): 108.7 in (276 cm)

(E-2F) - Mulching head working width (*): 90.7 in (231 cm)

(* - Specs for FAE 300U225 head; Dimensions will vary if other type of head is selected)

CMI Mulching inc.
1200 Chemin Herman-Lavigne | Saint-Cyrille-De-Wendover, QC, Canada J1Z 1S4
819 397-2288 | www.cmimulching.com

C.M.I. reserves the right to change specifications, design and price of products described in this literature without notice. C.M.I. and C400L are registered trademarks of C.M.I. Danri inc. Printed in Canada.

C400L



The Mulching Specialists

PERFORMANCE | RELIABILITY | SIMPLICITY

C400L

POWERFUL, HIGH DRIVE AND LIGHT WEIGHT
THE CMI C400L IS A PROVEN VALUE FOR VARIOUS APPLICATIONS

- MULCHING
- SUBSOILING
- STUMP GRINDING



HIGH EFFICIENCY COOLING PACKAGE WITH COARSE FINNS FOR EASY CLEANING

HIGH DRIVE TO KEEP MOVING PARTS EASY TO CLEAN AND AWAY FROM DIRT

IMPROVED TRACTION/POWER FOR BETTER HANDLING IN SOFT AND STEEP TERRAIN

NEW CAB



NEW DIGITAL SCREEN FOR EASY DATA ACCESS AND DIAGNOSTIC
NEW ERGONOMIC LAYOUT
12 VOLTS DC OUTLET

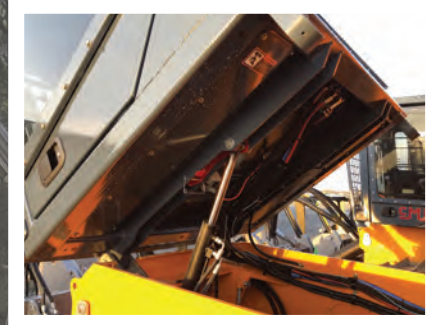

PUSH BUTTON CAB TILT FOR EASY ACCESS TO COMPONENTS & HYDRAULIC OIL FILLING PUMP

AM/FM/BLUETOOTH RADIO
AIR SUSPENSION SEAT

PRESSURISED CABIN WITH INTEGRATED HEAVY DUTY PRE-CLEANER



GREAT VISIBILITY

PERSONALIZED CONFIGURATION:
CONFIGURE WITH S400 STUMP GRINDER OR THE TYPE OF MULCHING HEAD THAT FITS YOUR APPLICATION BEST

UNIQUE CMI DOZER DESIGN TRACK FRAME PROVEN FOR DECADES IN THE PIPELINE INDUSTRY

FULL ROCK GUARD PROTECTION

